

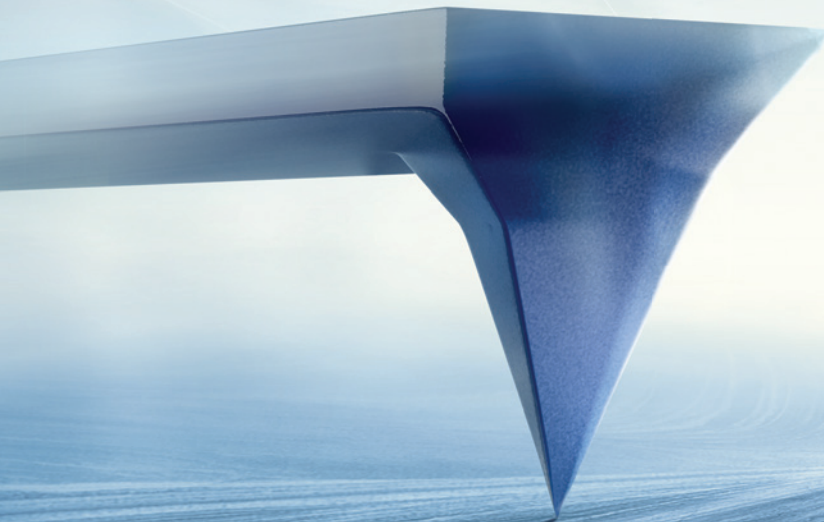

SPM PROBES & TEST STRUCTURES

MikroMasch® product catalogue



MikroMasch® HQ SPM Tips

- Tip sharpness better than 10 nm
- High Q-factor and smooth resonance curves
- Ideal reflectivity from the backside of the cantilever
- Alignment grooves for all single cantilever probes



MikroMasch® SPM Probes & Test Structures

www.spmtips.com

MikroMasch® Headquarters

Innovative Solutions Bulgaria Ltd.

48 Joliot Curie St.
1113 Sofia, Bulgaria
phone: +359 2 865-8629
fax: +359 2 963-0732
info@mikromasch.com
sales@mikromasch.com

MikroMasch® Europe

NanoAndMore GmbH

Spilburg Bld. A1, Steinbühlstrasse 7
D-35578 Wetzlar,
Germany
phone: +49 (0) 6441 2003561
fax: +49 (0) 6441 2003562
europe@mikromasch.com

MikroMasch® USA

NanoAndMore USA Corp.

21 Brennan Street, Suite 10
Watsonville, CA 95076, USA
Toll Free (US): +1 866 SPMTIPS (776-8477)
phone: +1 831-536-5970
fax: +1 831-475-4264
usa@mikromasch.com

MikroMasch® Distributor

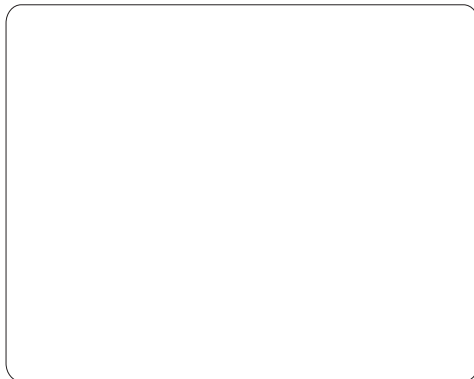

MikroMasch® is a trademark of NanoWorld AG operated by ISB Ltd.

Silicon Nitride Probes

NEW

We are happy to announce the introduction of MikroMasch Silicon Nitride XNC12 series* of AFM probes. These probes are intended for contact mode measurements on biological and other soft matter specimen. The main features of the back side gold coated XNC12/Cr-Au BS and the overall gold coated XNC12/Cr-Au models are as follows:

- 2 triangular silicon nitride cantilevers with 0.08 N/m and 0.32 N/m on each side of the holder chip
- Square pyramid silicon nitride tips with typical radii 10 nm (uncoated) and 30 nm (gold coated)
- Chip size 3.4 * 1.6 * 0.5 mm

We always listen to our customers and make sure to provide you with what you need for your AFM research. The XNC12 probes are now available for sale through all our distribution channels.

* See specifications on page 15

HQ Probes

The HQ Line (High Quality Line) is MikroMasch well-established state-of-the-art manufacturing and quality control technology. HQ probes are distinguished by their high quality and repeatability of characteristics. In particular, the probes have very consistent tip shape and radius, cantilever stiffness and resonance frequency, and laser reflectivity even for uncoated cantilevers.

RADIUS OF CURVATURE

The radius of curvature measures the sharpness of a particular probe. Typically, the sharper the curvature radius the more fragile a silicon tip is. Conversely, a larger curvature radius provides greater durability, but reduces the benefits of a sharper tip.

Achieving a consistent balance delivers reliable and accurate results. 94% of HQ probes have a radius of curvature between 7 and 10 nm.

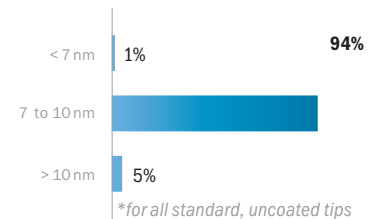

TIP SHAPE FACTOR

A higher value indicates a higher aspect ratio probe. A tighter range of values indicates a more consistent tip shape.

Results of the tip shape factor tests show consistent and close grouping of data. Known tip shape insures accuracy of results. 92% of HQ probes have an aspect ratio between 1.4 and 1.8.

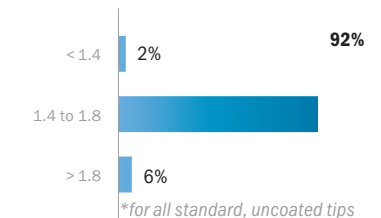

RESONANCE FREQUENCY

Probes are designed to maintain a tight range of resonance frequencies. Reliability in cantilever specifications ensures dependable measurement results.

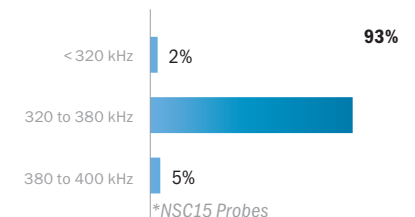

The New HQ Line & Test Structures

- Probe chip specifications 5
- REGULAR**
Noncontact and Contact silicon probes 6
- HIGH RESOLUTION**
Hi'Res-C: High Resolution silicon probes 8
- LONG SCANNING / LIFETIME**
Hardened DLC coated silicon probes 9
- CONDUCTIVE**
Conductive Noncontact and Contact silicon probes 10
DPER: High Resolution Conductive silicon probes 12
DPE: Low Noise Conductive silicon probes 13
- MAGNETIC**
Magnetic Noncontact silicon probes 14
- SILICON NITRIDE PROBES**
Silicone Nitride SPM Probes 15
- TIPLESS**
Noncontact and Contact Tipless silicon probes 16
- MIX & MATCH**
Mix&Match 17
- TEST STRUCTURES**
TGXYZ Series Calibration standards 18
TGX Series Calibration standards 18
TGF11 Series Calibration standards 19
PA Series Calibration standards 19
HOPG. 20
- RECOMMENDATIONS**
Recommendations for specific applications 22

HQ:NSC/CSC 1 - lever

Cantilever material n-type silicon
 Tip shape pyramidal
 Tip height 12 - 18 μ m
 Alignment grooves on the back side of the chip

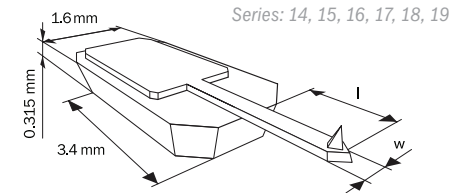

HQ:XSC 4 - lever

Cantilever material n-type silicon
 Tip shape pyramidal
 Tip height 12 - 18 μ m

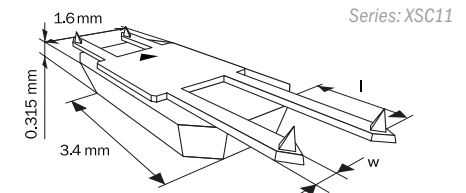

HQ:NSC/CSC 3 - lever

Cantilever material n-type silicon
 Tip shape pyramidal
 Tip height 12 - 18 μ m

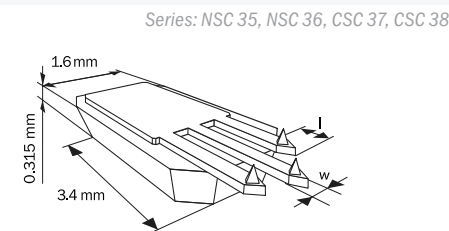

HQ: NSC/CSC Tipless 3 - lever

Cantilever material n-type silicon

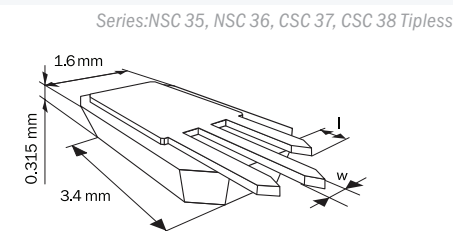

XNC12 4 - lever

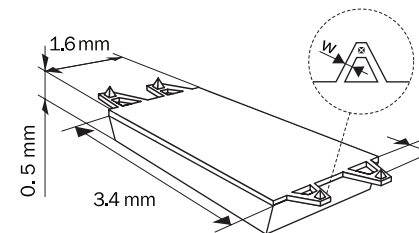

Cantilever material silicon nitride
 Tip shape pyramidal
 Tip height 3.5 μ m

Series: XNC 12

HQ: NSC, CSC & XSC

Noncontact (NSC), Contact (CSC) and 4 - Lever (XSC) silicon probes

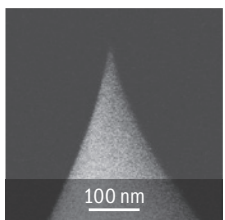

SEM image of the regular silicon tip

Pyramidal silicon etched probes* are characterized by high tip sharpness and narrow resonance peaks, making them very suitable for topography imaging in dynamic AFM modes and compositional mapping. These probes are available in a wide range of resonance frequencies and spring constants.

Tip properties:

Tip radius ~ 8 nm
 Tip material silicon

Back side coating:

Al BS Al 30 nm
 no Al none
 Cr-Au BS . . . Au 30 nm on Cr 20 nm sublayer

Cantilever Series	Available Coatings	Length l, ± 5 µm	Width w, ± 3 µm	Thickness ± 0.5 µm	Resonance Frequency		Force Constant	
					(typical)	(range)	(typical)	(range)
NSC								
HQ:NSC14	/No Al, /Al BS	125	25	2.1	160	110 - 220	5.0	1.8 - 13
HQ:NSC15	/No Al, /Al BS, /Cr-Au BS	125	30	4.0	325	265 - 410	40	20 - 80
HQ:NSC16	/No Al, /Al BS	225	37.5	7.0	190	170 - 210	45	30 - 70
HQ:CSC17	/No Al, /Al BS	450	50	2.0	13	10 - 17	0.18	0.06 - 0.40
HQ:NSC18	/No Al, /Al BS, /Cr-Au BS	225	27.5	3.0	75	60 - 90	2.8	1.2 - 5.5
HQ:NSC19**	/No Al, /Al BS	125	22.5	1.0	65	25 - 120	0.5	0.05 - 2.3
CSC								
HQ:NSC35								
lever A		110	35	2.0	205	130 - 290	8.9	2.7 - 24
lever B	/No Al, /Al BS, /Cr-Au BS	90	35	2.0	300	185 - 430	16	4.8 - 44
lever C		130	35	2.0	150	95 - 205	5.4	1.7 - 14
HQ:NSC36								
lever A		110	32.5	1.0	90	30 - 160	1.0	0.1 - 4.6
lever B	/No Al, /Al BS, /Cr-Au BS	90	32.5	1.0	130	45 - 240	2	0.2 - 9
lever C		130	32.5	1.0	65	25 - 115	0.6	0.06 - 2.7
XSC								
HQ:CSC37								
lever A		250	35	2.0	40	30 - 55	0.8	0.3 - 2
lever B	/No Al, /Al BS	350	35	2.0	20	15 - 30	0.3	0.1 - 0.6
lever C		300	35	2.0	30	20 - 40	0.4	0.1 - 1
HQ:CSC38								
lever A		250	32.5	1.0	20	8 - 32	0.09	0.01 - 0.36
lever B	/No Al, /Al BS	350	32.5	1.0	10	5 - 17	0.03	0.003 - 0.13
lever C		300	32.5	1.0	14	6 - 23	0.05	0.005 - 0.21
4-L								
HQ:XSC11								
lever A		500	30	2.7	15	12 - 18	0.2	0.1 - 0.4
lever B	/No Al, /Al BS	210	30	2.7	80	60 - 100	2.7	1.1 - 5.6
lever C		150	30	2.7	155	115 - 200	7	3 - 16
lever D		100	50	2.7	350	250 - 465	42	17 - 90

**ScanAsyst® compatible - ScanAsyst® is a trade mark of Bruker Corp.

APPLICATION

Phase imaging is among the AFM techniques that can be used to determine nanoscale differences in the properties of a heterogeneous system or of samples with inherent heterogeneity. Phase contrast is dependent on interactions between the tip and the sample, but those interactions are in turn partially dependent on the scan parameters and whether the image is being taken in an attractive or repulsive mode. O'Dea and Burrato used phase imaging to map the proton-conducting domains of a Nafion membrane. They found that the specific interaction forces between the tip and the sample significantly affected the resolution of the proton conducting domains. Imaging in a repulsive regime resulted in an overestimation of the area of the domains and an underestimation in the number of domains. Imaging in an attractive regime resulted in the most accurate phase imaging of the aqueous and fluorocarbon domains of the membrane. When the feedback loop was not optimized or the cantilever was driven above resonance, the phase corresponded with changes in topography rather than changes in the composition of the sample.

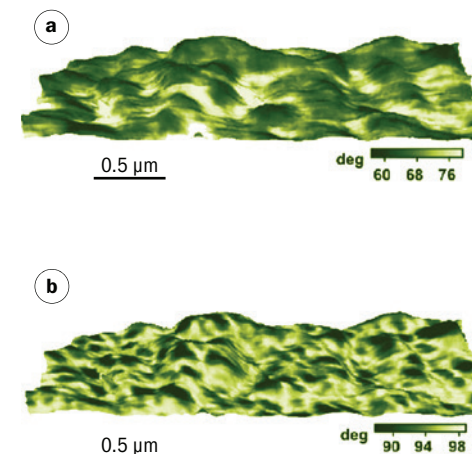

In figures (a) and (b) the phase data from repulsive and attractive regimes, respectively, have been overlaid on the corresponding topography image. Features of the phase contrast in the repulsive regime correspond to some features in the topography, while the phase contrast in the attractive regime is independent of the topography. Images were taken with the NSC15/Al BS (now upgraded to HQ:NSC15/Al BS). (O'Dea, J.R. and Burrato, S.K.; J. Phys. Chem. B 2011, 115, 1014-1020.)

PART NUMBER	HQ: * SC * / * - *	N, C, X	type
		11, 14, 15, 16, 17, 18, 19, 35, 36, 37, 38	series
		15, 50, 100, 200, 400	quantity*
		/No Al, /Al BS, /Cr-Au BS	coating

* Please refer to our price list for available package sizes.

Hi'Res-C

High Resolution silicon probes

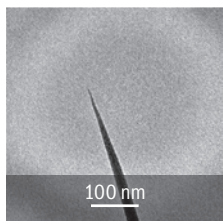

SEM image of the Hi'Res-C spike

The Hi'Res-C probes* suffer less contamination than silicon probes and are capable of obtaining many high-resolution scans, although they do require special care in use. Due to the small tip curvature radius, the tip-sample attraction force is minimized.

Advantages of Hi'Res-C are noticeable when scanning small areas (< 250 nm) and flat samples ($R_s < 20$ nm). On larger images, the resolution is similar to that of General Purpose probes.

Spike radius < 1 nm **Overall coating:**
Spike height 100 - 200 nm Au overall coating 30 nm
Spike material diamond-like Cr overall sublayer 20 nm
The coating does not cover the spike!

Cantilever Series	Available Coatings	Length l, ± 5 µm	Width w, ± 3 µm	Thickness ± 0.5 µm	Resonance Frequency		Force Constant	
					(typical)	(range)	(typical)	(range)
Hi'Res-C14	/Cr-Au	125	25	2.1	160	110 - 220	5.0	1.8 - 13
Hi'Res-C15	/Cr-Au	125	30	4.0	325	265 - 410	40	20 - 80
Hi'Res-C18	/Cr-Au	225	27.5	3.0	75	60 - 90	2.8	1.2 - 5.5
Hi'Res-C19**	/Cr-Au	125	22.5	1.0	65	25 - 120	0.5	0.05 - 2.3

* See specifications on page 5

**ScanAsyst® compatible - ScanAsyst® is a trade mark of Bruker Corp.

APPLICATION

The advantages of the Hi'Res-C probes are noticeable on scans less than 250 nm in size. The tip radius of 1 nm allows high resolution imaging of nanometer-sized objects like single molecules, ultrathin films, and porous materials in air.

(a) Height image of polydiacetylene crystal obtained with Dimension 5000 SPM microscope and Hi'Res-C probe. Scan size 15 nm. A single defect in the molecular lattice of PDA crystal is visible. (b) Height image of PDA crystal obtained with Agilent 5500 SPM microscope and Hi'Res-C14 probe. Scan size 23 nm. Molecular lattice of PDA is observed only.

Images courtesy of Dr. S. Magonov, Agilent Technologies.

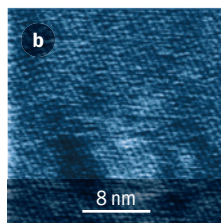
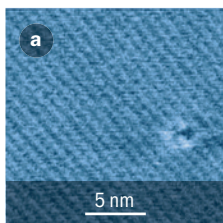

PART NUMBER	Hi'Res - C * / Cr-Au - *	14, 15, 19	series
		5	quantity

Series HARD

Hardened DLC coated silicon probes

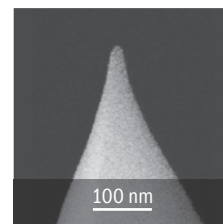

SEM image of the HARD tip

The HARD series silicon etched probe* tips have pyramidal shape. The probes are coated with a hard DLC film. The Back side of the cantilevers is coated with the 30 nm aluminium reflective film.

Typical tip radius < 20 nm
Tip side coating. DLC 20 nm
Back side coating Al 30 nm

Cantilever Series	Available Coatings	Length l, ± 5 µm	Width w, ± 3 µm	Thickness ± 0.5 µm	Resonance Frequency		Force Constant	
					(typical)	(range)	(typical)	(range)
HQ:NSC14	/Hard/Al BS	125	25	2.1	160	110 - 220	5.0	1.8 - 13
HQ:NSC15	/Hard/Al BS	125	30	4.0	325	265 - 410	40	20 - 80
HQ:NSC16	/Hard/Al BS	225	37.5	7.0	190	170 - 210	45	30 - 70
HQ:CSC17	/Hard/Al BS	450	50	2.0	13	10 - 17	0.18	0.06 - 0.40
HQ:NSC18	/Hard/Al BS	225	27.5	27.5	75	60 - 90	2.8	1.2 - 5.50

HQ:NSC35								
lever	Available Coatings	Length	Width	Thickness	Resonance Frequency	Force Constant		
		l, ± 5 µm	w, ± 3 µm	± 0.5 µm	kHz (typical) (range)	N/m (typical) (range)		
lever A	/Hard/Al BS	110	35	2.0	205	130 - 290	8.9	2.7 - 24
lever B		90	35	2.0	300	185 - 430	16	4.8 - 44
lever C		130	35	2.0	150	95 - 205	5.4	1.7 - 14

HQ:NSC36								
lever	Available Coatings	Length	Width	Thickness	Resonance Frequency	Force Constant		
		l, ± 5 µm	w, ± 3 µm	± 0.5 µm	kHz (typical) (range)	N/m (typical) (range)		
lever A	/Hard/Al BS	110	32.5	1.0	90	30 - 160	1.0	0.1 - 4.6
lever B		90	32.5	1.0	130	45 - 240	2	0.2 - 9
lever C		130	32.5	1.0	65	25 - 115	0.6	0.06 - 2.7

* See specifications on page 5

APPLICATION

The wear-resistant diamond-like carbon (DLC) coating increases tip durability and lifetime. DLC coated probes are useful for scanning large areas and very hard materials.

PART NUMBER	HQ: * SC * / Hard / Al BS - *	N, X, C	type
		15, 50	quantity
		11, 14, 15, 16, 17, 18, 35, 36	series

Pt and Cr-Au Coated

Conductive Noncontact (NSC), Contact (CSC) and 4 - Lever (XSC) silicon probes

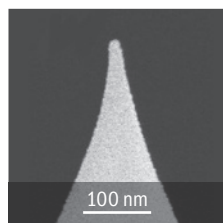

SEM image of the conducting silicon tip

Pyramidal silicon etched probes* with conductive platinum or gold coatings are suitable for a wide range of electrical applications of AFM. Gold and platinum coatings are inert, which makes these probes applicable for many experiments in biology and chemistry.

Pt coated resulting tip radius < 30 nm **Cr-Au coated resulting tip radius < 35 nm**
 Pt overall coating 30 nm Au overall coating 30 nm
 Cr overall sublayer 20 nm

Cantilever Series	Available Coatings	Length l, ± 5 µm	Width w, ± 3 µm	Thickness ± 0.5 µm	Resonance Frequency		Force Constant	
					(typical)	(range)	(typical)	(range)
NSC								
HQ:NSC14	/Cr-Au, /Pt	125	25	2.1	160	110 - 220	5.0	1.8 - 13
HQ:NSC15	/Cr-Au, /Pt	125	30	4.0	325	265 - 410	40	20 - 80
HQ:NSC16	/Cr-Au,	225	37.5	7.0	190	170 - 210	45	30 - 70
HQ:CSC17	/Cr-Au, /Pt	450	50	2.0	13	10 - 17	0.18	0.06 - 0.40
HQ:NSC18	/Cr-Au, /Pt	225	27.5	3.0	75	60 - 90	2.8	1.2 - 5.5
HQ:NSC19**	/Cr-Au	125	22.5	1.0	65	25 - 120	0.5	0.05 - 2.3
CSC								
HQ:NSC35								
lever A		110	35	2.0	205	130 - 290	8.9	2.7 - 24
lever B	/Cr-Au, /Pt	90	35	2.0	300	185 - 430	16	4.8 - 44
lever C		130	35	2.0	150	95 - 205	5.4	1.7 - 14
HQ:NSC36								
lever A		110	32.5	1.0	90	30 - 160	1.0	0.1 - 4.6
lever B	/Cr-Au, /Pt	90	32.5	1.0	130	45 - 240	2	0.2 - 9
lever C		130	32.5	1.0	65	25 - 115	0.6	0.06 - 2.7
4-lever								
HQ:CSC37								
lever A		250	35	2.0	40	30 - 55	0.8	0.3 - 2
lever B	/Cr-Au, /Pt	350	35	2.0	20	15 - 30	0.3	0.1 - 0.6
lever C		300	35	2.0	30	20 - 40	0.4	0.1 - 1
HQ:CSC38								
lever A		250	32.5	1.0	20	8 - 32	0.09	0.01 - 0.36
lever B	/Cr-Au	350	32.5	1.0	10	5 - 17	0.03	0.003 - 0.13
lever C		300	32.5	1.0	14	6 - 23	0.05	0.005 - 0.21
4:1								
HQ:XSC11								
lever A		500	30	2.7	15	12 - 18	0.2	0.1 - 0.4
lever B	/Pt	210	30	2.7	80	60 - 100	2.7	1.1 - 5.6
lever C		150	30	2.7	155	115 - 200	7	3 - 16
lever D		100	50	2.7	350	250 - 465	42	17 - 90

**ScanAsyst® compatible - ScanAsyst® is a trade mark of Bruker Corp.

* See specifications on page 5

APPLICATION

AFM is capable of mapping different electric properties of materials to topography images. These data can be used for analysis of the structure and composition of heterogeneous samples as well as for quantitative characterization of individual grains or defects on the surface. Electric properties of a sample can be mapped using probes with conducting coatings, when AC or DC bias is applied between the tip and the sample. Contact mode or two-pass operation techniques can be used for this purpose.

Although traditional piezoelectric and ferroelectric materials are often the samples studied using piezoresponse force microscopy, Minary-Jolandan and Yu showed that the electromechanical properties of collagen fibrils can also be investigated with PFM. They found via high resolution PFM with a Pt coated CSC17 probe (now upgraded to HQ:CSC17/Pt) that collagen fibrils have piezoelectrically heterogeneous gap and overlap regions. The gap regions exhibit little to no piezoelectricity, while the overlap regions show piezoelectricity. Images (a) and (d) show the topography of the collagen fibril, while (b) and (e) show the PFM amplitude. (c) and (f) are the 2ω signal measured to rule out any electrostatic interference with the PFM signal. The Pt only coating on the CSC17 probe (now upgraded to HQ:CSC17/Pt) allowed for the resolution of features ~30 nm. (Minary-Jolandan, M. and Yu, M.-F.; ACS Nano 2009, 3, 1859-1863.)

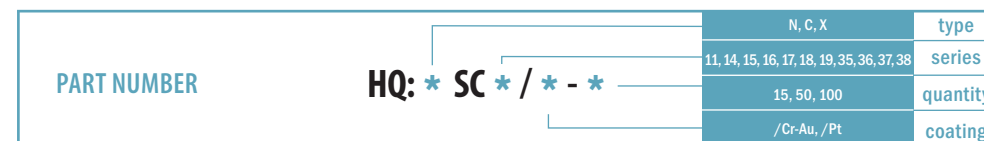
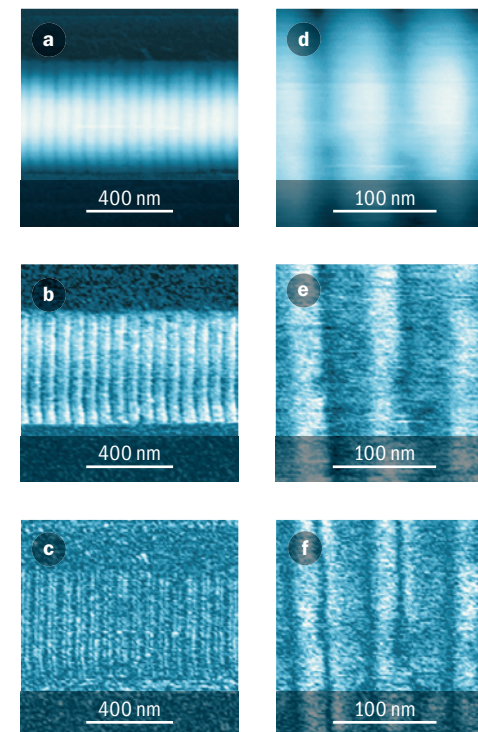

DPER

High Resolution Conductive silicon probes

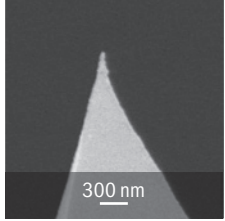

DPER probes* are made by depositing a thin platinum coating on silicon tips. While the thickness of the coating on a flat cantilever surface is about 15 nm, there is only a 10 nm increase in the tip dimensions compared to bare silicon probes. These probes are recommended for electrical applications requiring higher resolution.

Pt coated resulting tip radius < 20 nm
Pt overall coating 15 nm

SEM image of the DPER silicon tip

Cantilever Series	Length l, ± 5 µm	Width w, ± 3 µm	Thickness ± 0.5 µm	Resonance Frequency		Force Constant	
				(typical)	(range)	(typical)	(range)
4x							
HQ:DPER-XSC11							
lever A	500	30	2.7	15	12 - 18	0.2	0.1 - 0.4
lever B	210	30	2.7	80	60 - 100	2.7	1.1 - 5.6
lever C	150	30	2.7	155	115 - 200	7	3 - 16
lever D	100	50	2.7	350	250 - 465	42	17 - 90

* See specifications on page 5

APPLICATION

Topography (a) and in-plane piezoelectric force response (b) images of an approximately 80 nm thick BiFeO₃ film grown on a LaAlO₃ substrate taken with a DPER18 probe (now replaced by HQ:DPE-XSC11).

Image courtesy of Zuhuang Chen, Nanyang Technological University.

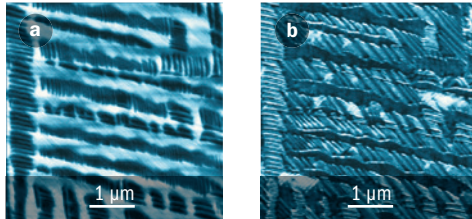

PART NUMBER	HQ: DPER - XSC11 - *	15, 50, 100	quantity
-------------	-----------------------------	-------------	----------

DPE

Low Noise Conductive silicon probes

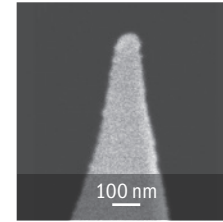

The DPE probes* feature silicon tips and a special structure of conductive layers, which provides a more stable electrical signal and less noise. However, some reduction in resolution for topography images is possible when using DPE probes due to the increased tip radius.

Pt coated resulting tip radius < 40 nm
Pt overall coating 50 nm

SEM image of the DPE silicon tip

Cantilever Series	Length l, ± 5 µm	Width w, ± 3 µm	Thickness ± 0.5 µm	Resonance Frequency		Force Constant	
				(typical)	(range)	(typical)	(range)
4x							
HQ:DPE-XSC11							
lever A	500	30	2.7	15	12 - 18	0.2	0.1 - 0.4
lever B	210	30	2.7	80	60 - 100	2.7	1.1 - 5.6
lever C	150	30	2.7	155	115 - 200	7	3 - 16
lever D	100	50	2.7	350	250 - 465	42	17 - 90

* See specifications on page 5

APPLICATION

DPE probe topography (a) and surface potential (b) images of a fluoroalkane (F₁₂H₂₀) on a Silicon substrate.

Image was taken using single-pass KFM with an Agilent 5500 by S. Magonov.

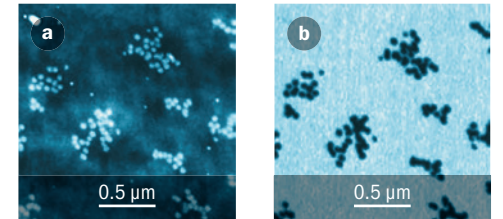

PART NUMBER	HQ: DPE - XSC11 - *	15, 50, 100	quantity
-------------	----------------------------	-------------	----------

Co-Cr Coated

Magnetic Noncontact (NSC) silicon probes

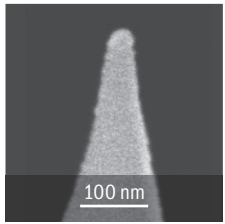

Two HQ:NSC probe* models are available with a special coating for Magnetic Force Microscopy. The coating consists of a 60 nm cobalt layer on the tip side and is protected from oxidation with a 20 nm chromium film. The cantilever parameters are optimized for stable measurements of topography and magnetic properties.

Co-Cr coated tip radius < 60 nm Back side Al coating 30 nm
 Co tip side coating 60 nm
 Cr tip side coating 20 nm Coercivity 300–400 Oe

SEM image of the magnetic silicon tip

Cantilever Series	Available Coatings	Length l, ± 5 µm	Width w, ± 3 µm	Thickness ± 0.5 µm	Resonance Frequency		Force Constant	
					(typical)	(range)	(typical)	(range)
HQ:NSC18	/Co-Cr/Al BS	225	27.5	3.0	75	60 - 90	2.8	1.2 - 5.5
HQ:NSC36								
lever A	/Co-Cr/Al BS	110	32.5	1.0	90	30 - 160	1.0	0.1 - 4.6
lever B		90	32.5	1.0	130	45 - 240	2	0.2 - 9
lever C		130	32.5	1.0	65	25 - 115	0.6	0.06 - 2.7

* See specifications on page 5

APPLICATION

Topography (a) and magnetic (b) images of a Co mono domain particle obtained in Lift Mode using a NSC36 series cantilever with Co-Cr coating (now upgraded to HQ:NSC36/Co-Cr/Al BS). Image courtesy of Prof. V. Shevyakov, MIET.

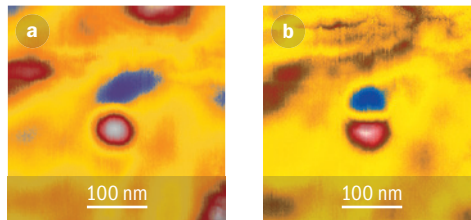

PART NUMBER	HQ: NSC * / Co-Cr / Al BS - *	18,36	series
		15, 50	quantity

Silicon Nitride Probes

Silicon Nitride Probes

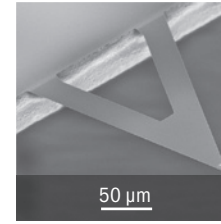

Probes of the 12 series have 2 silicon nitride cantilevers and tips on each side of the glass holder chip. They are used for soft contact mode applications.

Tip side coating:
 Cr-Au BS none
 Cr-Au 35 nm, Au on Cr

Back side coating:
 Cr-Au BS 70 nm, Au on Cr
 Cr-Au 70 nm, Au on Cr

Cr-Au BS uncoated tip radius ~ 10 nm
Cr-Au coated tip radius ~ 30 nm

SEM image of a XNC12 Cantilever

Cantilever Series	Available Coatings	Length l, ± 10 µm	Width w, ± 5 µm	Thickness ± 0.075 µm	Resonance Frequency		Force Constant	
					(typical)	(range)	(typical)	(range)
XNC12								
lever A	Cr-Au / Cr-Au BS	200	28	0.5	17	-	0.08	-
lever B		100	13.5	0.5	67	-	0.32	-

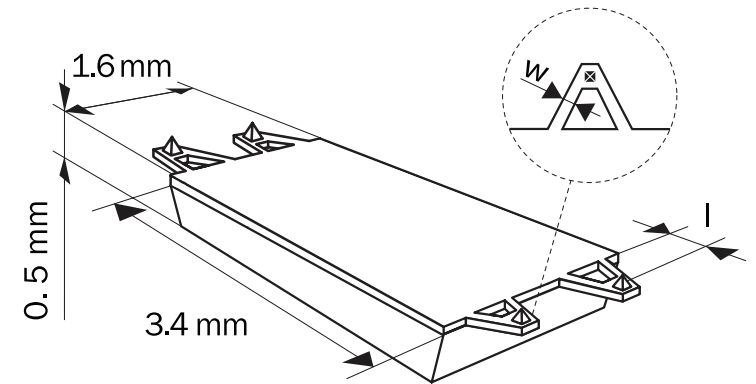
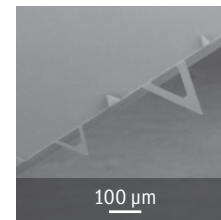
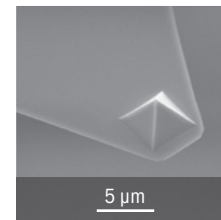

PART NUMBER	XNC12 / * - *	10, 35, 70	quantity
		/Cr-Au, /Cr-Au BS	coating

Tipless Cantilevers

Tipless Noncontact (NSC) and Contact (CSC) three-lever silicon probes

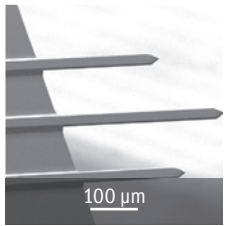

SEM image of a tipless silicon cantilever

Probes of the Tipless Series feature 3 tipless cantilevers* with different spring constants and resonance frequencies on one side of the chip. This series replaces the former 12 Series.

Back side coating:

Al BS. Al 30 nm
no Al. no

Cr-Au coated

Au overall coating 30 nm
Cr overall sublayer 20 nm

Cantilever Series	Available Coatings	Length l, ± 5 μm	Width w, ± 3 μm	Thickness ± 0.5 μm	Resonance Frequency kHz		Force Constant N/m	
					(typical)	(range)	(typical)	(range)
HQ:NSC35/Tipless								
lever A	/No Al, /Al BS, /Cr-Au	110	35	2.0	205	130 - 290	8.9	2.7 - 24
lever B		90	35	2.0	300	185 - 430	16	4.8 - 44
lever C		130	35	2.0	150	95 - 205	5.4	1.7 - 14
HQ:NSC36/Tipless								
lever A	/No Al, /Al BS, /Cr-Au	110	32.5	1.0	90	30 - 160	1.0	0.1 - 4.6
lever B		90	32.5	1.0	130	45 - 240	2	0.2 - 9
lever C		130	32.5	1.0	65	25 - 115	0.6	0.06 - 2.7
HQ:CSC37/Tipless								
lever A	/No Al, /Al BS, /Cr-Au	250	35	2.0	40	30 - 55	0.8	0.3 - 2
lever B		350	35	2.0	20	15 - 30	0.3	0.1 - 0.6
lever C		300	35	2.0	30	20 - 40	0.4	0.1 - 1
HQ:CSC38/Tipless								
lever A	/No Al, /Al BS, /Cr-Au	250	32.5	1.0	20	8 - 32	0.09	0.01 - 0.36
lever B		350	32.5	1.0	10	5 - 17	0.03	0.003 - 0.13
lever C		300	32.5	1.0	14	6 - 23	0.05	0.005 - 0.21

* See specifications on page 5

APPLICATION

Tipless cantilevers can be used for measurements of material properties and interactions. Different objects such as glass spheres or polystyrene particles can also be mounted on tipless cantilevers to make them applicable for AFM-like experiments.

PART NUMBER	HQ: * SC * / Tipless / * - *	N, C	type
		35, 36, 37, 38	series
		15, 50, 100, 200, 400	quantity*
		/No Al, /Al BS, /Cr-Au	coating

* Please refer to our price list for available package sizes.



DISCOUNTS UP TO 40%

IN YOUR OWN PERSONALIZED BOX WITH DIFFERENT MIKROMASCH® AFM PROBES

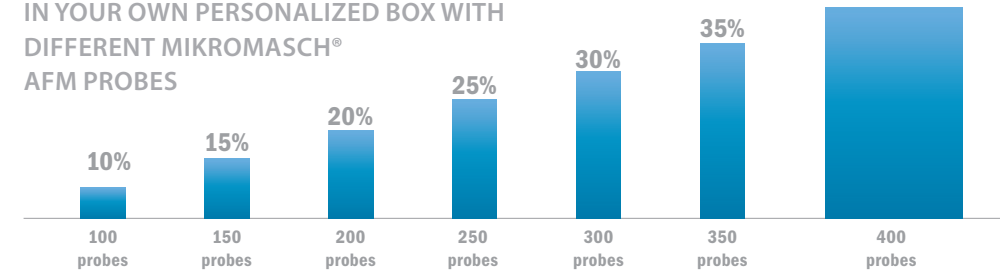

Mix and Match enables you to create a custom MikroMasch® AFM probes box with quantities of 100, 150, 200, 250, 300, 350 or 400 pcs. inside where you can mix different MikroMasch® AFM probe types in units of 50 pcs.

The more units of 50 AFM probes you order, the higher your discount will be from the 50 probes list prices of each variety ordered:



YOU CAN CREATE YOUR OWN MIKROMASCH® BOX USING THE FORM ON OUR WEBSITE. WE WILL SHIP YOUR PERSONAL MIX AND MATCH BOX WITHIN 10 BUSINESS DAYS.

TGXYZ Series

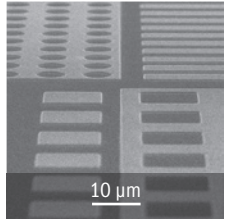

SEM image of a TGXYZ02 grating

Calibration gratings from the TGXYZ series are arrays of different structures comprising rectangular silicon dioxide steps on a silicon wafer. The small square in the center with dimensions 500 µm by 500 µm includes circular pillars and holes, as well as lines in the X- and Y-direction with a pitch of 5 µm. The large square with dimensions 1 mm by 1 mm contains square pillars and holes with a pitch of 10 µm.

Active area 1 x 1 mm
Chip dimensions5x5x0.3 mm

Part number	Step height*	Height accuracy	Pitch	Pitch accuracy
TGXYZ01	20 nm	2%	5 and 10 µm	0.1 µm
TGXYZ02	100 nm	3%	5 and 10 µm	0.1 µm
TGXYZ03	500 nm	3%	5 and 10 µm	0.1 µm

The dimensions marked * are given for reference only. The actual step height, shown on the label of the individual grating box may differ slightly from the nominal value.

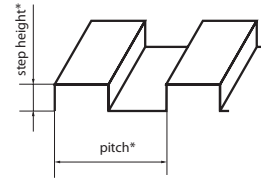

APPLICATION

The TGXYZ calibration gratings are intended for vertical and lateral calibration of SPM scanners. The vertical non-linearity can be compensated for by using several calibration gratings with different nominal step heights.

TGX Series

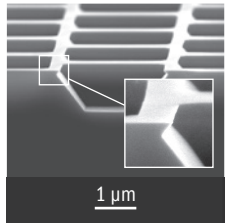

SEM image of a TGX01 grating

The silicon calibration grating TGX is an array of square holes with sharp undercut edges formed by anisotropic etching along the (111) crystallographic planes of silicon. The typical radius of the edges is less than 5 nm.

Part number TGX

Active area 1 x 1 mm
Chip dimensions5 x 5 x 0.3 mm
Edge radii < 5 nm
Pitch 3 µm
Pitch accuracy 0.1 µm
Step height* 1 µm

The dimensions marked * are given for reference only.

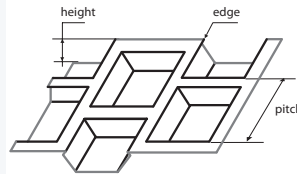

TGX calibration gratings are intended for determination of the tip aspect ratio and for lateral calibration of SPM scanners. The gratings can also be used for detection of lateral non-linearity, hysteresis, creep, and cross-coupling effects.

Please note: The TGXYZ, TGX, TGF11, and PA Series Calibration Gratings are available either mounted on a round metal plate with Ø12mm or unmounted. For ordering information visit www.spmtips.com

TGF11 Series

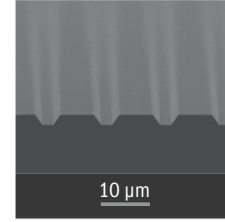

SEM image of a TGF11 grating

The TGF calibration gratings feature one-dimensional arrays of trapezoidal steps etched into a silicon substrate. The sidewalls of the structures are very smooth and planar surfaces with well-defined orientation formed by the (111) crystallographic planes in monocrystalline silicon. The sidewalls and the horizontal top surfaces form an angle of 54.74°.

Part number TGF11

Active area 3 x 3 mm
Chip dimensions5 x 5 x 0.3 mm
Pitch 10 µm
Pitch accuracy 0.1 µm
Step height* 1.75 µm

The step height value is given for information only, not for vertical calibration purposes.

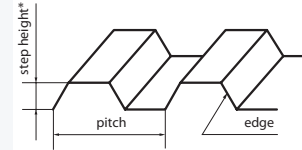

APPLICATION

TGF11 grating can be used for the assessment of scanner nonlinearity in the vertical direction. Direct calibration of the lateral force can be obtained by analyzing the contact response measured on the flat and sloped facets. This can be done for the calibration of conventional Si probes or cantilevers with an attached colloidal particle with any radius of curvature up to 2 µm.

PA Series

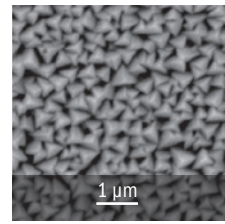

SEM image of a PA01 structure
Scan size 1 µm

Sample for characterization of tip shape with hard sharp pyramidal nanostructures. The structures are covered by a highly wear-resistant layer.

Part number PA01

Pyramid base 50 - 100 nm
Pyramid height 50 - 150 nm
Smallest edge radii < 5 nm
Active area 5 x 5 mm
Chip dimensions 5 x 5 x 0.3 mm

APPLICATION

The exact shape of the scanning probe tip is very important for obtaining AFM images of high quality and accuracy. As new AFM tips with nanometer radii of curvature become widespread, periodic structures that have surface features of similar or greater sharpness should be used to estimate the parameters of the tip.

Please note: The TGXYZ, TGX, TGF11, and PA Series Calibration Gratings are available either mounted on a round metal plate with Ø12mm or unmounted. For ordering information visit www.spmtips.com

HOPG

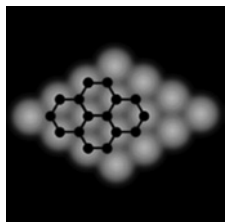

Typical STM image of HOPG with superimposed graphene structure

Highly ordered pyrolytic graphite (HOPG) is a lamellar material and consists of stacked planes. Carbon atoms within a single plane interact more strongly than with those in adjacent planes. Each atom within a plane has three nearest neighbors, resulting in a honeycomb-like structure. This two-dimensional single-atom thick plane is called graphene.

Part number:

HOPG/ZYA/DS/1-1	10 x 10 x 1 mm, 1 chip
HOPG/ZYA/DS/2-1	10 x 10 x 2 mm, 1 chip
HOPG/ZYB/DS/1-1	10 x 10 x 1 mm, 1 chip
NEW HOPG/ZYB/DS/2-1	10 x 10 x 2 mm, 1 chip
HOPG/ZYH/DS/1-1	10 x 10 x 1 mm, 1 chip
HOPG/ZYH/DS/2-1	10 x 10 x 2 mm, 1 chip
HOPG/ZYH/DS/1-5	10 x 10 x 1 mm, 5 chips
HOPG/ZYH/DS/2-5	10 x 10 x 2 mm, 5 chips

Density 2.266 g/cm³

Thermal conductivities:

thermal conductivity parallel (002)1700 ± 100 W/(m·K)
thermal conductivity perpendicular (002)8 ± 1 W/(m·K)
electrical conductivity parallel (002)	2.1 ± 0.1 x 10 ⁶ [(Ω·m) ⁻¹]
electrical conductivity perpendicular (002)	5 x 10 ² [(Ω·m) ⁻¹]

There are several grades of single - or double sided HOPG with thickness 1 mm or more:

	ZYA Grades	ZYB Grades	ZYH Grades
Mosaic spread	0.4°±0.1°	0.8°±0.2°	3.5°± 1.5°

APPLICATION

HOPG terminated with a graphene layer can serve as an ideal atomically flat surface to be used as a substrate or standard for SPM investigations. This is also an easily “cleavable” material with a smooth surface, which is vital for SPM measurements that require a uniform, flat and clean substrate.



Notes section with a grid of dotted lines for writing.



PLEASE NOTE

The TGXYZ, TGX, TGF11, and PA Series Calibration Gratings are available either mounted on a round metal plate with Ø12mm or unmounted. For ordering information visit www.spmtips.com

RECOMMENDATIONS FOR SPECIFIC APPLICATIONS

	Probe Type	Characteristics	k , N/m	f_0 , kHz	Tip Material, Coating	R_{tip} , nm
Materials characterization	HQ:NSC18	Force modulation	~2.8	~75	Silicon, Al or no Al Back side coating	~8
	HQ:NSC14	Phase imaging	~5.0	~150	Silicon, Al or no Al Back side coating	~8
General topology imaging	HQ:NSC17	Contact imaging	~0.18	~13	Silicon, Al or no Al Back side coating	~8
	HQ:NSC15	Intermittent/non-contact Imaging	~40	~325	Silicon, Al or no Al Back side coating	~8
	HQ:NSC14	Intermittent contact imaging	~5.0	~150	Silicon, Al or no Al Back side coating	~8
	HQ:NSC19	Intermittent contact imaging / ScanAsyst @ PeakForce tapping™ *	~0.5	~65	Silicon, Al or no Al Back side coating	~8
Topology imaging for life science	HQ:NSC14	Intermittent contact imaging	~5.0	~150	Silicon, Al or no Al Back side coating	~8
	HQ:NSC18/ Cr-Au BS	Intermittent contact imaging in fluid	~2.8	~75	Silicon, Au Back side coating	~8
	HQ:NSC18/Cr-Au BS	Contact imaging in fluid	~2.8	~75	Silicon, Au Back side coating	~8
	HQ:CSC17	Contact imaging	~0.18	~13	Silicon, Al or no Al Back side coating	~8
	HQ:CSC38 (three lever)	Contact imaging	~0.09 ~0.03 ~0.05	~20 ~10 ~14	Silicon, Al or no Al Back side coating	~8
	Hi'Res-C14/Cr-Au	High resolution Imaging	~5.0	~160	Carbon spike, Al Back side coating	~1
	HQ:NSC36 (three lever)	Intermittent contact imaging	~1.0 ~2.0 ~0.6	~90 ~130 ~65	Silicon, Al or no Al Back side coating	~8
	XNC12/Cr-Au BS (four lever)	Soft contact mode imaging	~0.08 ~0.32	~17 ~67	Silicon Nitride, Au Back side coating	<40
	XNC12/Cr-Au (four lever)	Soft contact mode imaging	~0.08 ~0.32	~0.08 ~0.32	Cr-Au coating on both sides	<60
	Probes for mechanical property measurements in life science	HQ:NSC14/Hard	Specially coated for durability	~5.0	~160	DLC coating, Al Back side coating
HQ:NSC18		Force modulation	~2.8	~75	Silicon, Al or no Al Back side coating	~8
HQ:CSC17/Cr-Au		Chemical inertness, functionalization	~0.18	~13	Cr-Au coating on both sides	<35
Probes for high resolution imaging	Hi'Res-C14/Cr-Au	Nanometer-sized objects like single molecules, ultrathin films, and porous materials in air	~5.0	~160	Carbon spike, Cr-Au coating on both sides (spike not coated)	~1

k – Force constant; f_0 – Resonance frequency

* ScanAsyst® and PeakForce Tapping™ are trademarks of Bruker Corporation

	Probe Type	Characteristics	k , N/m	f_0 , kHz	Tip Material, Coating	R_{tip} , nm
Electrical applications in vacuum	HQ:DPER/XS11, Cantilever A	High resolution	~0.2	~15	Pt coating on both sides	<20
	HQ:DPE/XSC11, Cantilever A	High sensitivity, low wear	~0.2	~15	Pt coating on both sides	<40
Electrical applications for PFM, TUNA, SCM, SSRM	HQ:DPER/XSC11, Cantilever C	High resolution	~7	~155	Pt coating on both sides	<20
	HQ:DPE/XSC11, Cantilever C	Dynamic/contact electrical mode, high sensitivity, low wear	~7	~155	Pt coating on both sides	<40
	HQ:CSC17/Cr-Au	Chemical inertness, functionalization	~0.15	~12	Cr-Au coating on both sides	<35
	HQ:NSC18/Pt	Dynamic/contact electrical mode	~2.8	~75	Pt coating on both sides	<30
Electrical applications for EFM, SKPM, Voltage Modulation, Scanning Impedance Microscopy, SGM	HQ:DPER/XSC11, Cantilever C	High resolution	~7	~155	Pt coating on both sides	<20
	HQ:DPE/XSC11, Cantilever C	Dynamic/contact electrical mode, high sensitivity, low wear	~7	~155	Pt coating on both sides	<40
	HQ:NSC14/Pt	General stability in conductive modes	~7	~155	Pt coating on both sides	<30
	HQ: NSC14/Cr-Au	Chemical inertness, functionalization	~7	~155	Cr-Au coating on both sides	<35
	HQ:DPER/XSC11, Cantilever B	High resolution	~2.7	~80	Pt coating on both sides	<20
	HQ:DPE/XSC11, Cantilever B	High sensitivity, low wear	~2.7	~80	Pt coating on both sides	<40
	HQ:NSC18/Pt	General stability in conductive modes	~2.8	~75	Pt coating on both sides	<30
	HQ:NSC18/Cr-Au	Chemical inertness, functionalization	~2.8	~75	Cr-Au coating on both sides	<35
Magnetic force microscopy	HQ:NSC18/Co-Cr/Al BS	Magnetic coating	~2.8	~75	Co-Cr coating, Al Back side coating	<90

k – Force constant; f_0 – Resonance frequency

Contacts

Toll Free (US): +1 866 SPMTIPS (776-8477)

Phone (EU): +49 (0) 6441 2003561

Headquarters: +359 (0) 2 865-8629

E-mail: info@mikromasch.com
sales@mikromasch.com



www.mikromasch.com

www.spmtips.com

MikroMasch® Headquarters
Innovative Solutions Bulgaria Ltd.

48, Joliot Curie Str.
1113 Sofia, Bulgaria
phone: +359 2 865-8629
fax: +359 2 963-0732
info@mikromasch.com
sales@mikromasch.com

MikroMasch® Europe
NanoAndMore GmbH

Spilburg Bld. A1,Steinbühlstrasse 7
D-35578 Wetzlar,
Germany
phone: +49 (0) 6441 2003561
fax: +49 (0) 6441 2003562
europe@mikromasch.com

MikroMasch® USA
NanoAndMore USA Corp.

21 Brennan Street, Suite 10
Watsonville, CA 95076, USA
Toll Free (US): +1 866 SPMTIPS (776-8477)
phone: +1 831-536-5970
fax: +1 831-475-4264
usa@mikromasch.com

MikroMasch® is a trademark of NanoWorld AG operated by ISB Ltd.

August 2017